

ME-709-00900

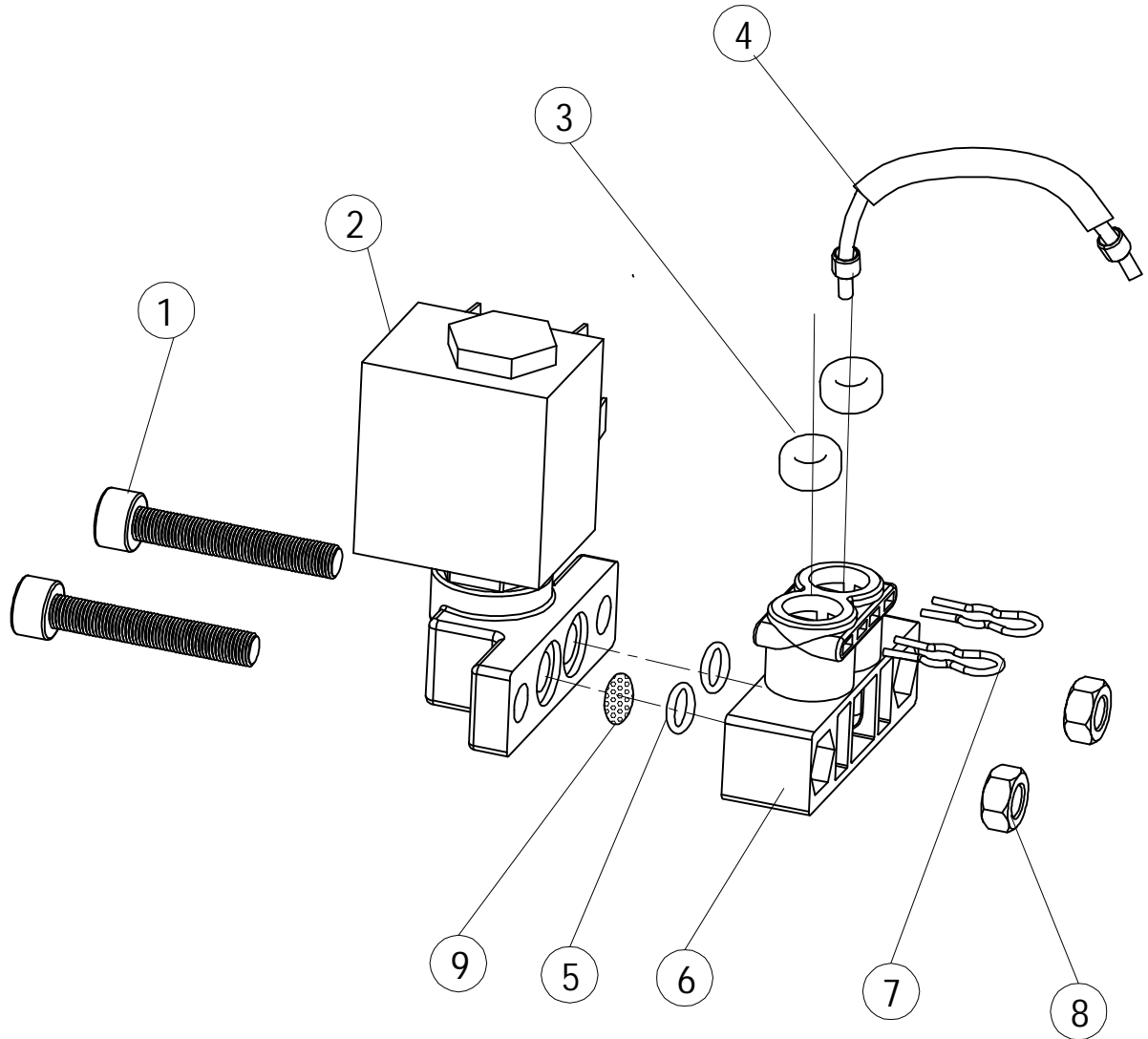

9	Solenoid filtrate net	ME-709-20101	SUS304	1	
8	Hex Nuts		ISOZ M5	2	
7	Steam Buckle 1		SUS304	2	
6	Solenoid Valve tie-in	ME-709-10117	PEI 1010	1	
5	Coffee spout tube O-ring	ME-707-31204	High tear Silicone	2	Φ5.6xΦ1.8
4	Teflon tube		Solenoid-Steam tube tie-in		
3	Pipe buckle O-ring	ME-707-30902	Dow Corning Silicone	2	∅3.6X1.8X3.6
2	Solenoid		JYZ-3	1	
1	Hexagon bolt		ISOP M5X35 ZI	1	
NO.	NAME	Dwg NO.	Material & Specification	Qty	Remark

					<b>Solenoid valve Subassembly</b>		<b>ME-709-00900</b>			
							Edition	VIEW	Qty	SCALE
Sign	Qty	File NO.	Signature	Date	1.0		1			
Design		Auditing			Current 1 sheet		Total 1 sheet			
Norm		Approve			Ningbo Merol Coffee Machines Co., Ltd.					